

The University of the State of New York
REGENTS HIGH SCHOOL EXAMINATION

PHYSICAL SETTING
EARTH SCIENCE

Friday, June 15, 2012 — 1:15 to 4:15 p.m., only

Use your knowledge of Earth science to answer all questions in this examination. Before you begin this examination, you must be provided with the *2011 Edition Reference Tables for Physical Setting/Earth Science*. You will need these reference tables to answer some of the questions.

You are to answer all questions in all parts of this examination. You may use scrap paper to work out the answers to the questions, but be sure to record your answers on your answer sheet and in your answer booklet. A separate answer sheet for Part A and Part B–1 has been provided to you. Follow the instructions from the proctor for completing the student information on your answer sheet. Record your answers to the Part A and Part B–1 multiple-choice questions on this separate answer sheet. Record your answers for the questions in Part B–2 and Part C in your separate answer booklet. Be sure to fill in the heading on the front of your answer booklet.

All answers in your answer booklet should be written in pen, except for graphs and drawings, which should be done in pencil.

When you have completed the examination, you must sign the declaration printed on your separate answer sheet, indicating that you had no unlawful knowledge of the questions or answers prior to the examination and that you have neither given nor received assistance in answering any of the questions during the examination. Your answer sheet and answer booklet cannot be accepted if you fail to sign this declaration.

Notice. . .

A four-function or scientific calculator and a copy of the *2011 Edition Reference Tables for Physical Setting/Earth Science* must be available for you to use while taking this examination.

The use of any communications device is strictly prohibited when taking this examination. If you use any communications device, no matter how briefly, your examination will be invalidated and no score will be calculated for you.

DO NOT OPEN THIS EXAMINATION BOOKLET UNTIL THE SIGNAL IS GIVEN.

Part A

Answer all questions in this part.

Directions (1–35): For each statement or question, choose the word or expression that, of those given, best completes the statement or answers the question. Some questions may require the use of the *2011 Edition Reference Tables for Physical Setting/Earth Science*. Record your answers on your separate answer sheet.

1 A Foucault pendulum appears to change its direction of swing because Earth

-  (1) is tilted on its axis
(2) is spinning on its axis
(3) has a curved surface
(4) has a density of 5.5 g/cm^3

2 The modern heliocentric model of planetary motion states that the planets travel around

-  (1) the Sun in slightly elliptical orbits
(2) the Sun in circular orbits
(3) Earth in slightly elliptical orbits
(4) Earth in circular orbits

3 To an observer on Earth, the Sun appears brighter than the star *Rigel* because the Sun is

-  (1) hotter than *Rigel*
(2) more luminous than *Rigel*
(3) closer than *Rigel*
(4) larger than *Rigel*

4 The cross section below represents four locations on a mountain. The arrow indicates the prevailing wind direction.

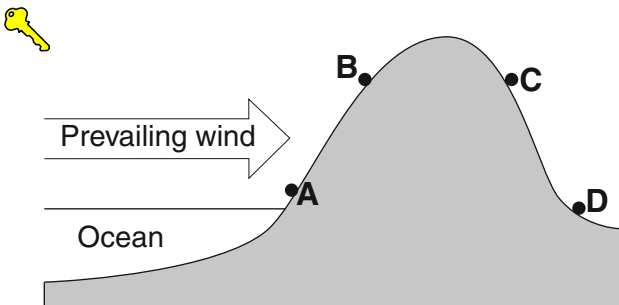

Which location has the warmest and most arid climate?

- (1) A (3) C
(2) B (4) D

5 The map below shows an eastern portion of North America. Points A and B represent locations on the eastern shoreline.



Which factor is primarily responsible for location A having a lower average yearly temperature than location B?

-  (1) nearness to a large body of water
(2) elevation
(3) latitude
(4) prevailing winds

6 El Cuy is a South American city located at 40° south latitude. The first day of winter at this location occurs on June 21. During which month would the coldest day of the year most likely occur at this location?

-  (1) May (3) November
(2) July (4) January

7 The map below shows a typical position and average velocity of the polar front jet stream during two different seasons.

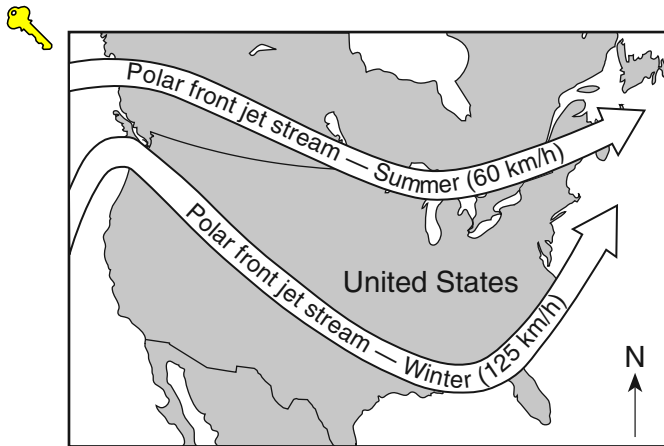

For the eastern United States, the change of the polar front jet stream from this summer position to this winter position causes

- (1) warmer temperatures farther north and causes storms to move more slowly
- (2) warmer temperatures farther north and causes storms to move more rapidly
- (3) cooler temperatures farther south and causes storms to move more slowly
- (4) cooler temperatures farther south and causes storms to move more rapidly

8 Which soil characteristic allows greater amounts of water retention?

- (1) large-size particles
- (2) small-size particles
- (3) high-density particles
- (4) low-density particles

9 A paved blacktop parking lot was built on what was once a soil-covered field. This area will now experience increased runoff when rain occurs because the paved parking lot has

- (1) less capillarity
- (2) less permeability
- (3) greater infiltration
- (4) greater porosity

10 Which processes of the water cycle return water vapor directly to the atmosphere?

- (1) evaporation and transpiration
- (2) infiltration and capillarity
- (3) freezing and precipitation
- (4) water retention and runoff

11 Evidence supports the idea that increases in carbon dioxide and methane in Earth's atmosphere are major contributors to global warming. This is based primarily on the fact that carbon dioxide and methane are excellent absorbers of

- (1) gamma rays
- (2) microwaves
- (3) visible light
- (4) infrared radiation

12 The bedrock of the Adirondack Mountains was formed mainly by the

- (1) cementation of clastic sediments and precipitates from seawater
- (2) compaction and recrystallization of volcanic material
- (3) regional metamorphism of sedimentary and igneous rocks
- (4) contact metamorphism of unconsolidated gravels

13 Which element, found in both biotite mica and muscovite mica, makes up the greatest percent by volume of Earth's crust?

- (1) nitrogen
- (2) oxygen
- (3) potassium
- (4) silicon

14 The inferred temperature and pressure of Earth's interior at a depth of 3,000 kilometers are approximately

- (1) 1000°C and 0.5 million atmospheres
- (2) 1000°C and 1.0 million atmospheres
- (3) 5000°C and 1.5 million atmospheres
- (4) 5000°C and 3.0 million atmospheres

15 Which agent of erosion most likely formed the drumlins and finger lakes in New York State?

- (1) running water
- (2) moving ice
- (3) wave action
- (4) mass movement

16 The longest portion of the Genesee River in New York State flows through which landscape region?

- (1) Erie-Ontario Lowlands
- (2) Tug Hill Plateau
- (3) Allegheny Plateau
- (4) St. Lawrence Lowlands

17 A model of Earth's internal structure is shown below.

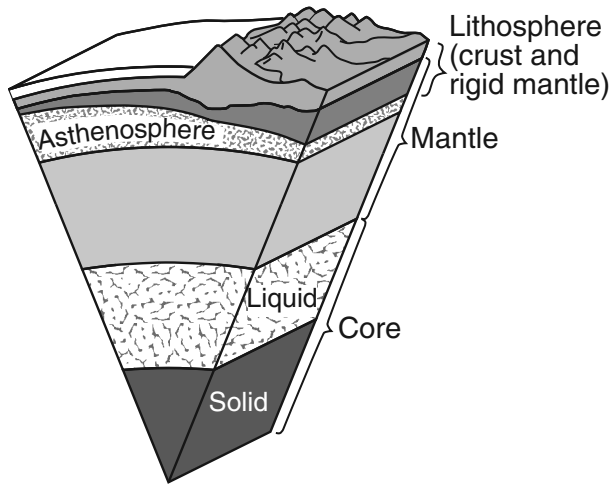

(Not drawn to scale)

Analysis of which type of data led to the development of this model?

- (1) seismic waves
- (2) depth of Earth's oceans
- (3) electromagnetic radiation
- (4) isobar gradients

18 What caused the interior of Earth to separate into layers?

- (1) a decrease in the rate of rotation of Earth
- (2) the gravitational pull on materials of varying densities
- (3) variations in heating by the Sun due to Earth's tilt
- (4) collisions with meteors and comets

19 Which plate tectonic events occurred as the Iapetus Ocean closed?

- (1) Taconian orogeny and Grenville orogeny
- (2) Taconian orogeny and Acadian orogeny
- (3) Alleghenian orogeny and Acadian orogeny
- (4) Alleghenian orogeny and Grenville orogeny

20 Which mineral will scratch fluorite, galena, and pyroxene?

- (1) graphite
- (2) calcite
- (3) olivine
- (4) dolomite

21 Which radioactive isotope is most often used when determining the age of fossil bones found in sediments deposited during the Holocene Epoch?

- (1) carbon-14
- (2) potassium-40
- (3) uranium-238
- (4) rubidium-87

22 The photograph below shows index fossil shells found in bedrock in New York State.

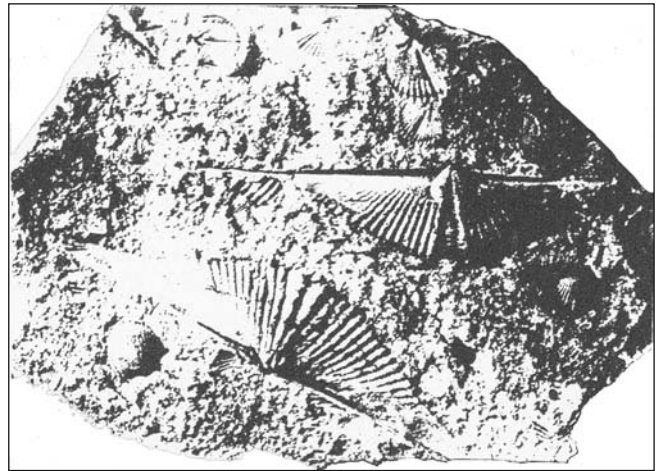

These index fossil shells were most likely found in the surface bedrock of which landscape region?

- (1) Adirondack Mountains
- (2) the Catskills
- (3) St. Lawrence Lowlands
- (4) Tug Hill Plateau

Base your answers to questions 23 and 24 on the weather map below, which represents a low-pressure system over New York State. The **L** on the map represents the center of the low-pressure system. Two fronts extend from the center of the low, and are labeled front 1 and front 2. Cloud cover has been omitted from the station models.

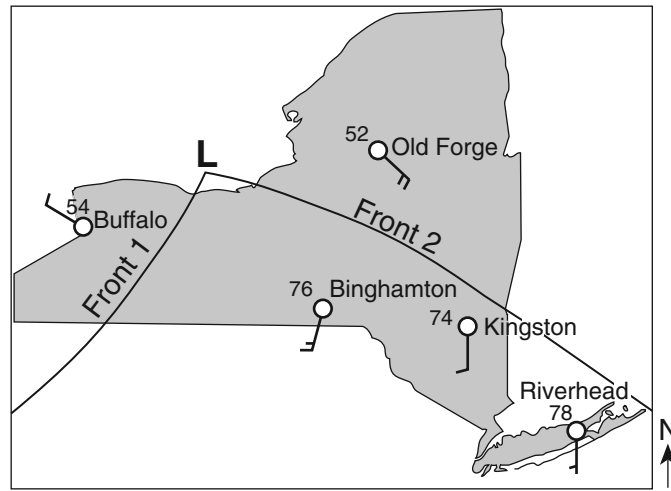

23 The arrows on which map best represent the surface wind pattern around this low-pressure center?

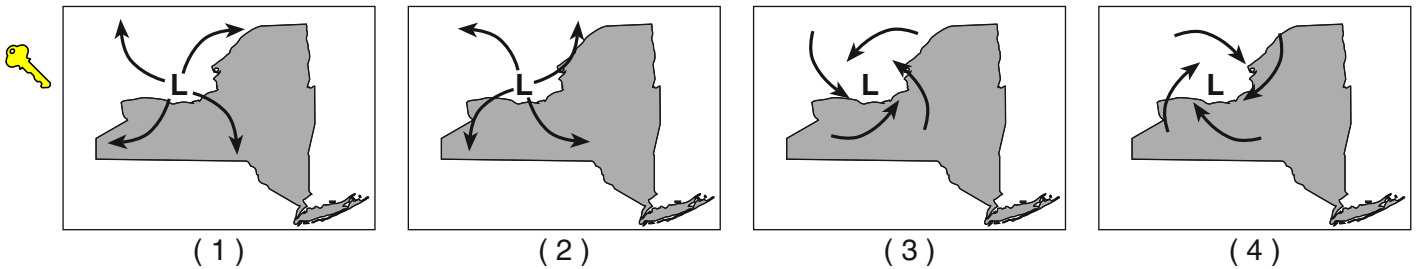

24 Which map best represents the type of fronts and direction of movement of these fronts in relation to the low-pressure center?

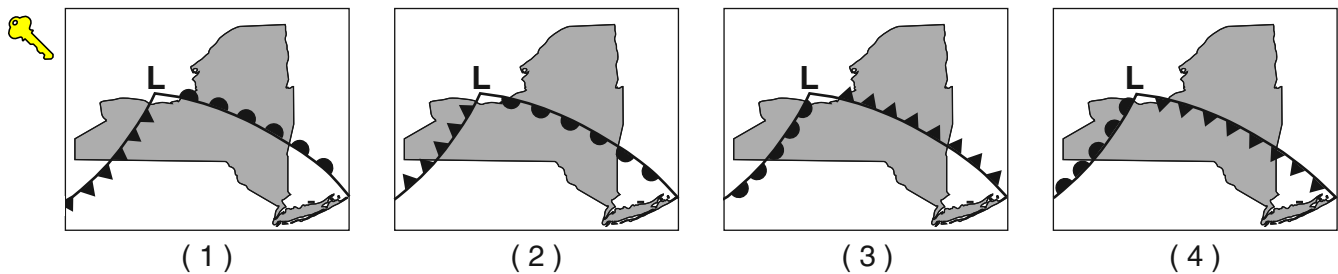

25 A timeline from the origin of Earth until the present is shown below.

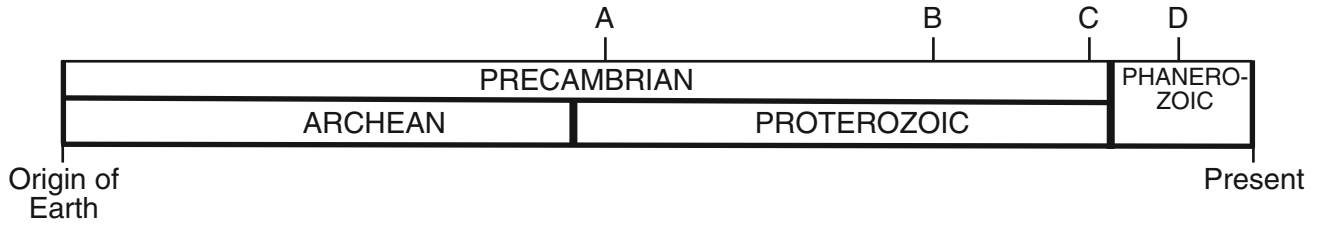

At which letter on the timeline did the Ediacaran fauna exist?

- (1) A (2) B (3) C (4) D

26 The diagram below represents three identical beakers filled to the same level with spherical beads.

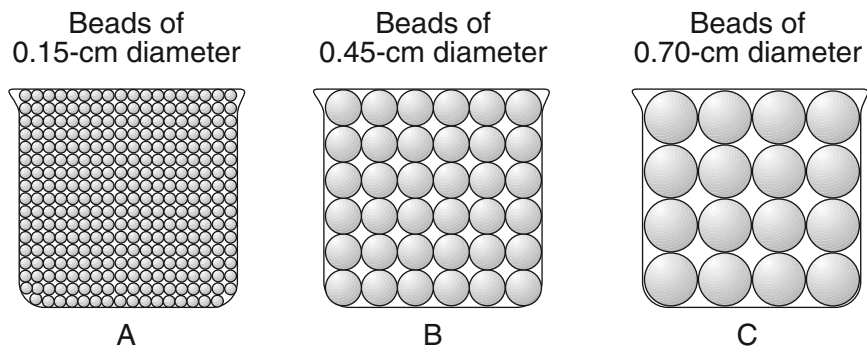

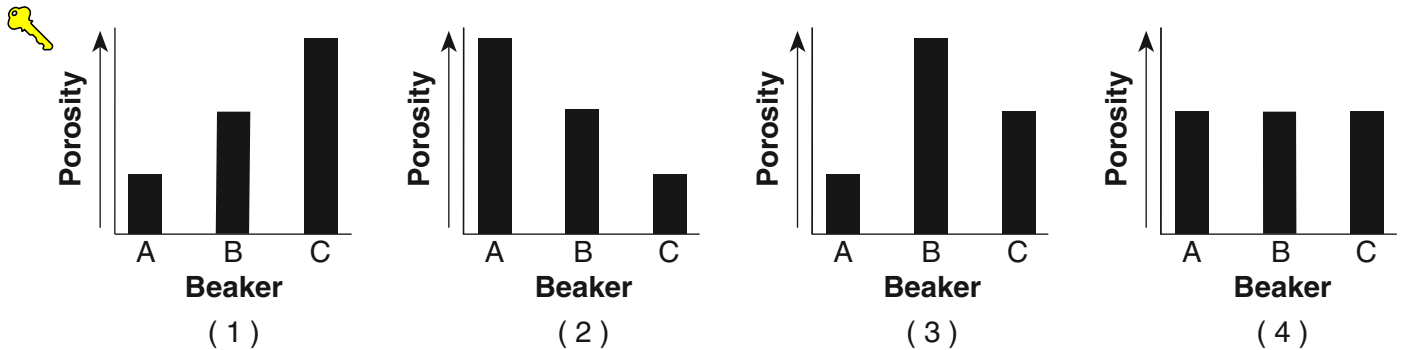

If the packing of the beads within each beaker is the same, which graph best represents the porosity within each beaker?



27 Which diagram correctly represents the curving of Earth's ocean currents and prevailing winds due to the Coriolis effect?



Key	
	= Ocean currents
	= Prevailing winds

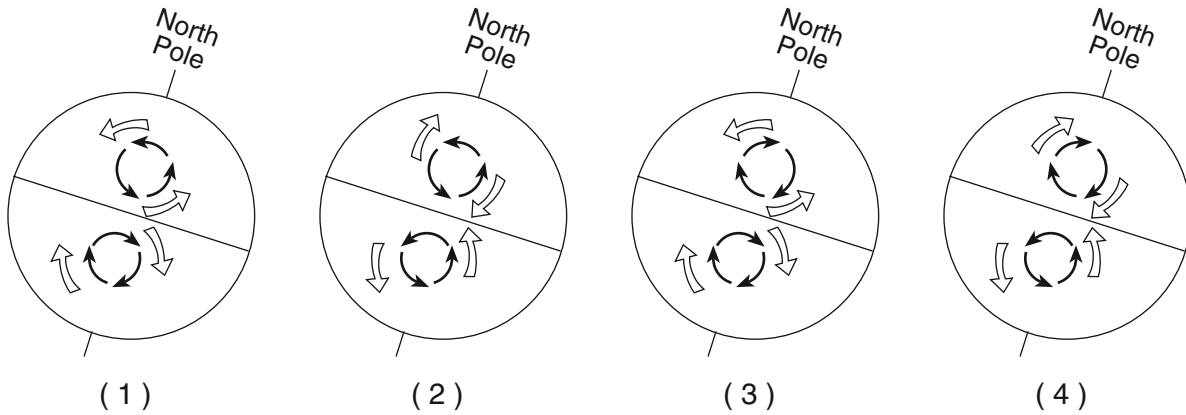

28 A topographic map and an *incorrectly* constructed profile from point A to point H on the map are shown below.

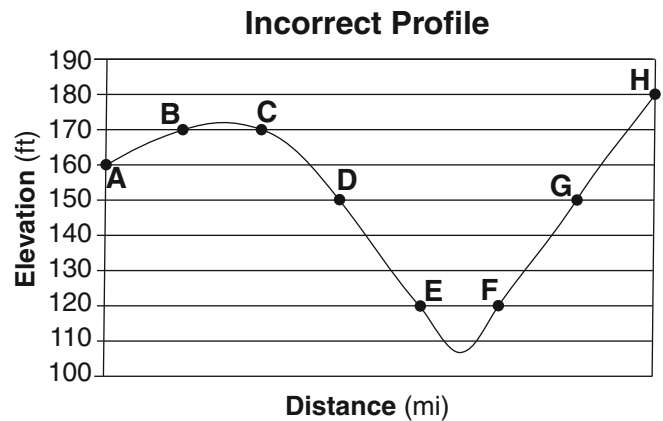
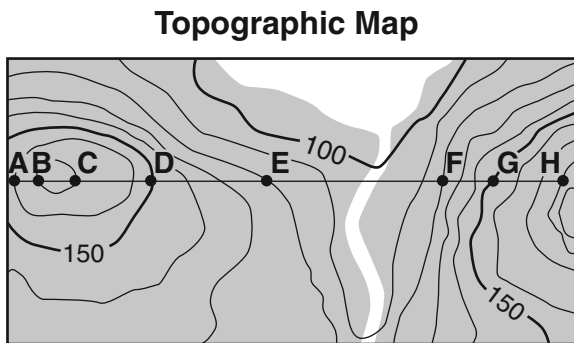

What mistake was made in the construction of this profile?



- (1) using a contour interval of 10 feet
- (2) plotting points A through H the same distance apart horizontally
- (3) drawing a curved line instead of a straight line from point B to point C
- (4) increasing the elevation from point F to point H

Base your answers to questions 29 and 30 on the map of the night sky below, which represents the apparent locations of some of the constellations that are visible to an observer at approximately 40° N latitude at 9 p.m. in April. The point directly above the observer is labeled zenith.

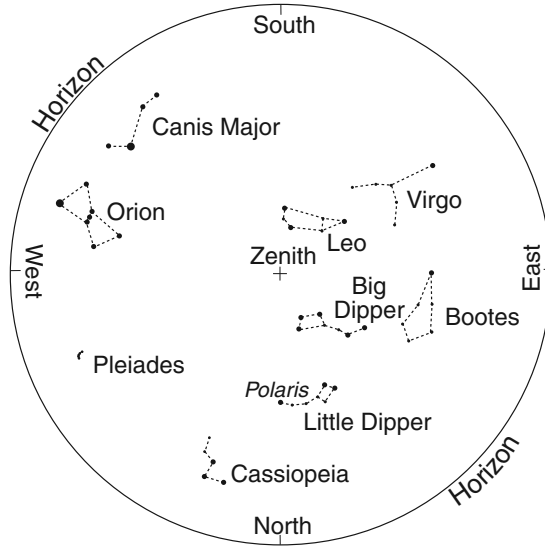

29 Which map best illustrates the apparent path of Virgo during the next 4 hours?

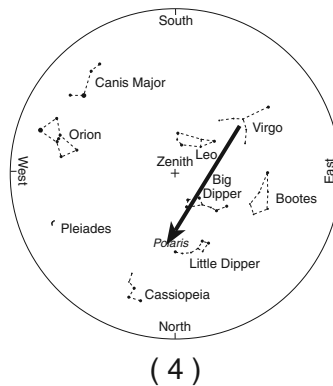
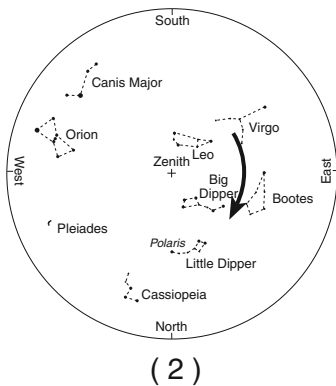
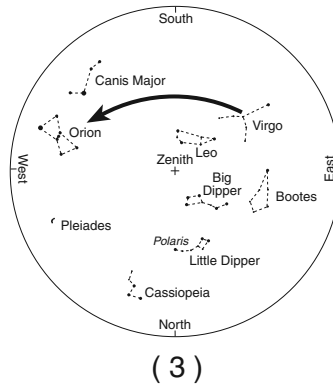
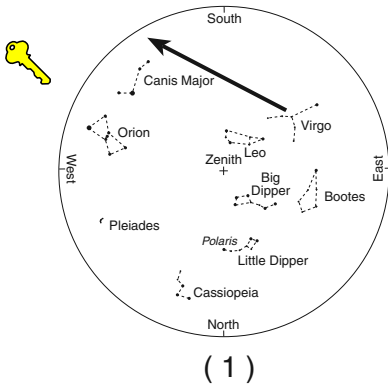

30 Which motion causes the constellation Leo to no longer be visible to an observer at 40° N in October?

- (1) spin of the constellation on its axis
- (2) revolution of the constellation around the Sun
- (3) spin of Earth on its axis
- (4) revolution of Earth around the Sun

- 31 An earthquake occurs at 12:02 p.m. A seismic station records the first S-wave at 12:19 p.m. Which set of data shows the approximate arrival time of the first P-wave and the distance to the epicenter?
- (1) 12:11:25 p.m. and 4000 km
 (2) 12:11:25 p.m. and 6000 km
 (3) 12:19:40 p.m. and 4000 km
 (4) 12:19:40 p.m. and 6000 km



- 32 The cross section below represents a portion of Earth's crust. Letters A through D are locations within the rock units.

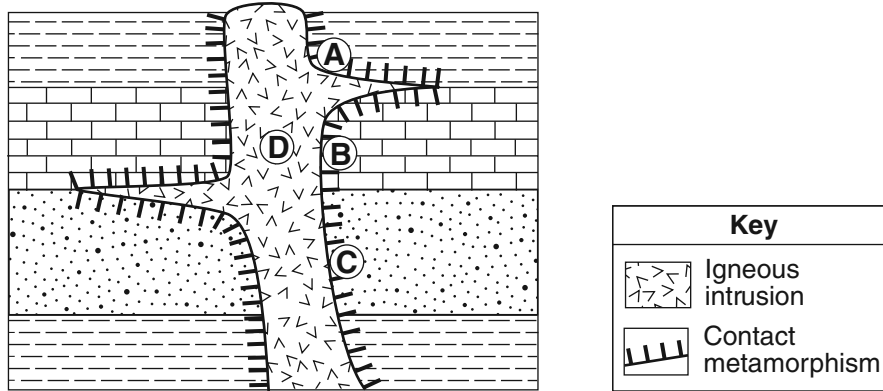

At which location is quartzite most likely found?



- (1) A
 (2) B
 (3) C
 (4) D

- 33 The diagram below represents a total solar eclipse as seen from Earth.

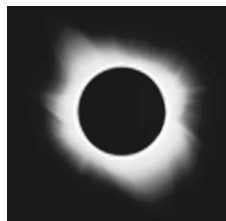

Which diagram correctly represents the relative positions of the Sun (S), Earth (E), and the Moon (M) in space during a total solar eclipse? [The diagrams are not drawn to scale.]

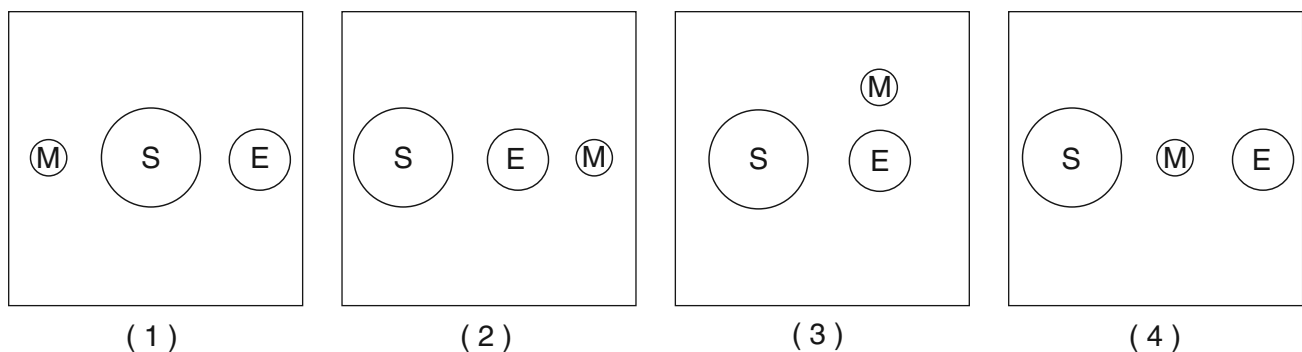

Base your answers to questions 34 and 35 on the diagram and data table below. The diagram shows the equipment used to determine the factors affecting the rate of erosion in a stream. The data table shows the time it took a 10-gram sample of quartz sand to move 100 centimeters down the rain gutter under various conditions.

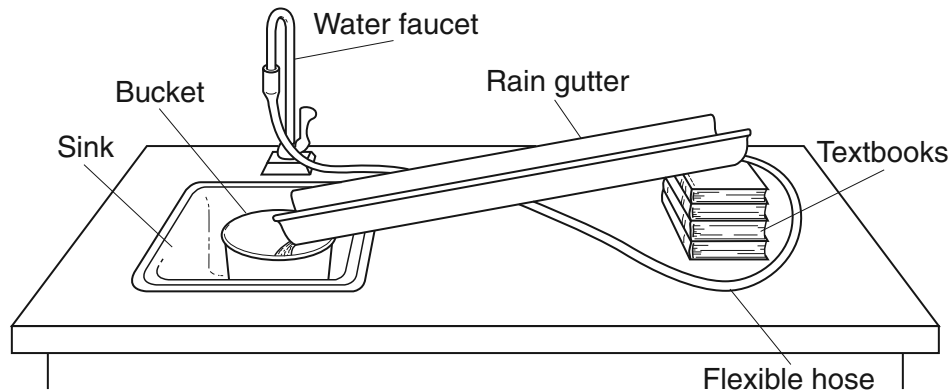

Data Table

Rain Gutter Slope	Water Velocity	Erosion Time (s)	
		Fine Sand	Coarse Sand
5°	slow	20	60
	fast	15	40
10°	slow	15	40
	fast	10	30
20°	slow	10	30
	fast	5	15

34 In this experiment, the water velocity could be increased by

- (1) decreasing the slope of the rain gutter
- (2) increasing the amount of water from the faucet
- (3) lowering the flexible hose
- (4) widening the rain gutter



35 What is the relationship between the water velocity and the rate of erosion?

- (1) If the water velocity decreases, the rate of erosion increases.
- (2) If the water velocity increases, the rate of erosion increases.
- (3) If the water velocity remains constant, the rate of erosion decreases.
- (4) If the water velocity remains constant, the rate of erosion increases.



Part B-1

Answer all questions in this part.

Directions (36–50): For *each* statement or question, choose the word or expression that, of those given, best completes the statement or answers the question. Some questions may require the use of the *2011 Edition Reference Tables for Physical Setting/Earth Science*. Record your answers on your separate answer sheet.

Base your answers to questions 36 and 37 on the diagrams below. The diagrams represent the events that occur when a large meteor, such as the one believed to have caused the extinction of many organisms, impacts Earth's surface. Diagram A shows the meteor just before impact. Diagram B represents the crater forming, along with the vapor and ejecta (the fragmented rock and dust) thrown into the atmosphere.

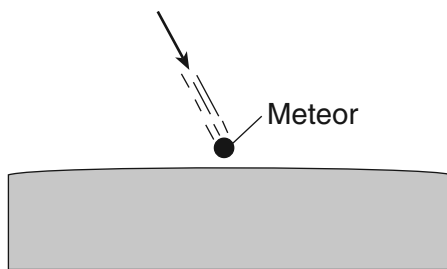

Diagram A: Before Impact

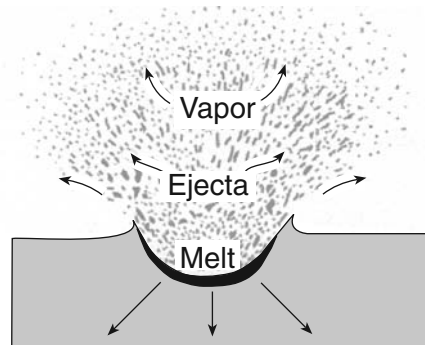



Diagram B: During Impact

36 Which statement best explains how global climate would most likely be affected after this large meteor impact?

- (1) Large quantities of ejecta in the atmosphere would block insolation and lower global temperatures.
-  (2) An increase in vapor and ejecta would allow radiation to escape Earth's atmosphere and lower global temperatures.
- (3) Ejecta settling in thick layers would increase the absorption of insolation by Earth's surface and raise global temperatures.
- (4) Forest fires produced from the vapor and ejecta would raise global temperatures.

37 Many meteors are believed to be fragments of celestial objects normally found between the orbits of Mars and Jupiter. These objects are classified as

-  (1) stars
- (2) asteroids
- (3) planets
- (4) moons

Base your answers to questions 38 through 41 on the diagram and data table below. The diagram represents the Sun's apparent paths as viewed by an observer located at 50° N latitude on June 21 and March 21. The data table shows the Sun's maximum altitude for the same two dates of the year. The Sun's maximum altitude for December 21 has been left blank.

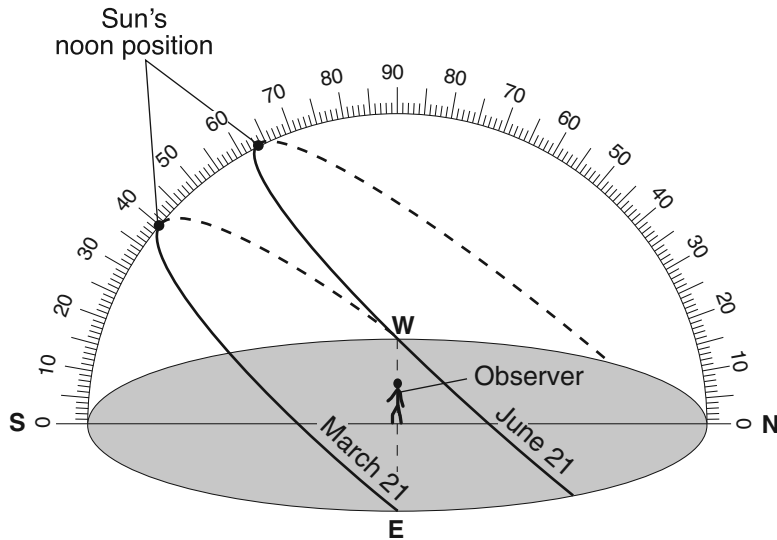

Data Table

Date	Sun's Maximum Altitude
June 21	63.5°
March 21	40°
December 21	

38 Which value should be placed in the data table for the Sun's maximum altitude on December 21?

- (1) 16.5°
- (2) 23.5°
- (3) 40°
- (4) 90°



39 Which graph best represents the relationship between the time of day and the length of a shadow cast by the observer on March 21?

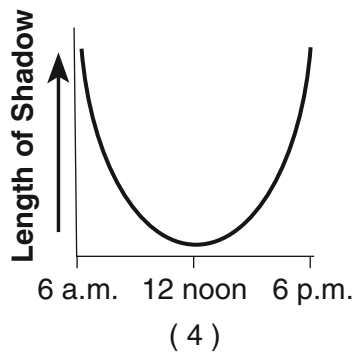
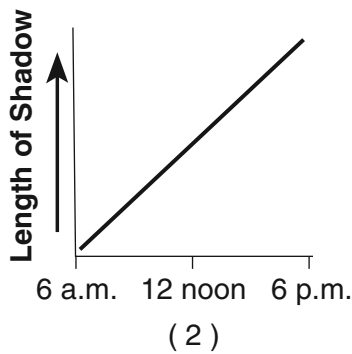
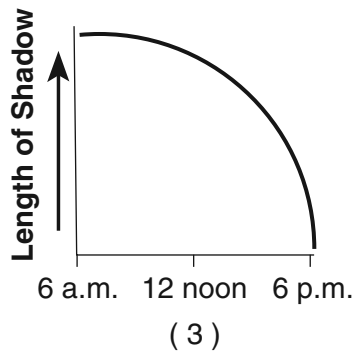
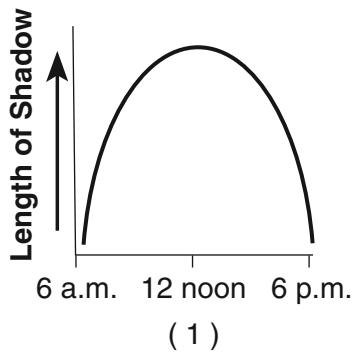

40 Which statement best compares the intensity and angle of insolation at noon on March 21 and June 21?

- (1) The intensity and angle of insolation are greatest on March 21.
- (2) The intensity and angle of insolation are greatest on June 21.
- (3) The intensity of insolation is greatest on June 21 and the angle of insolation is greatest on March 21.
- (4) The intensity of insolation is greatest on March 21 and the angle of insolation is greatest on June 21.



41 Which diagram represents the approximate location of the Sun at 3 p.m. on March 21?

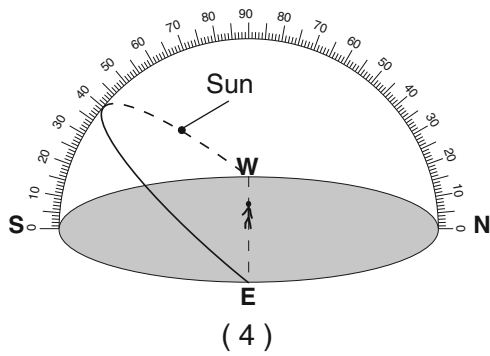
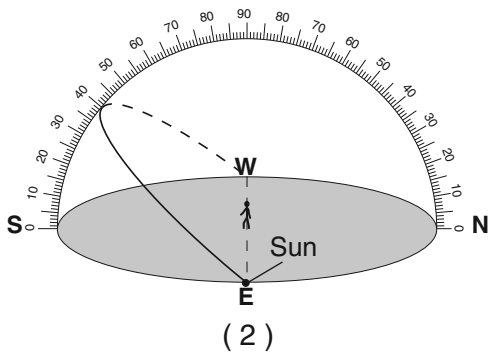
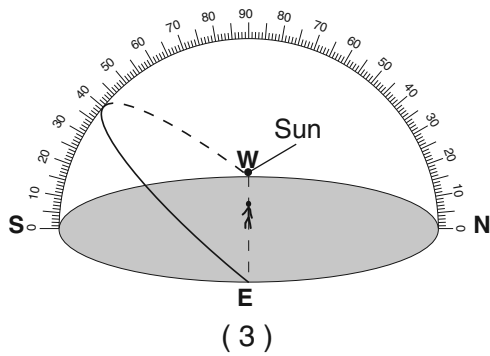
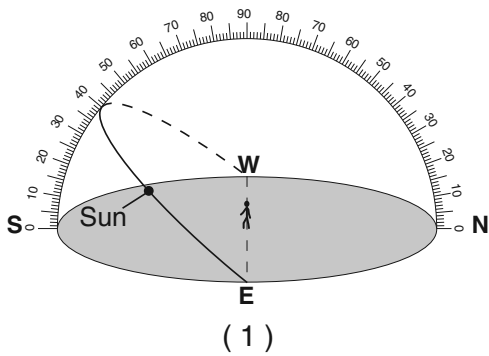

Base your answers to questions 42 through 45 on the laboratory experiment described below.

The weathering of four different rock samples with different masses was studied. Each rock sample was placed in a separate beaker containing 500 milliliters of a dilute acid for 10 minutes. Bubbling was observed in some of the beakers. The data table below shows the mass of each sample, in grams, before placement in the acid and after removal from the acid.

Data Table

Rock	Mass Before (g)	Mass After (g)
limestone	19.72	19.64
granite	20.77	20.77
gneiss	26.83	26.83
marble	20.81	20.73

42 Which Earth process is being modeled in this experiment?

- (1) physical weathering in the hydrosphere
- (2) physical weathering in the mesosphere
- (3) chemical weathering in the hydrosphere
- (4) chemical weathering in the mesosphere



43 Which table correctly shows the classification of the rock samples based on the amount of weathering during this experiment?



Group A	Group B
limestone marble	granite gneiss

(1)

Group A	Group B
limestone	granite marble gneiss

(3)

Group A	Group B
limestone granite gneiss	marble

(2)

Group A	Group B
limestone granite	gneiss marble

(4)

44 Approximately what percentage of the marble sample remained after the experiment?

- (1) 0.4%
- (2) 8.0%
- (3) 20.7%
- (4) 99.6%



45 Which property of the gneiss sample prevented it from weathering?

- (1) crystalline texture
- (2) mineral composition
- (3) density
- (4) cleavage



Base your answers to questions 46 through 48 on the topographic map below. Points A, X, and Y are reference points on the map.

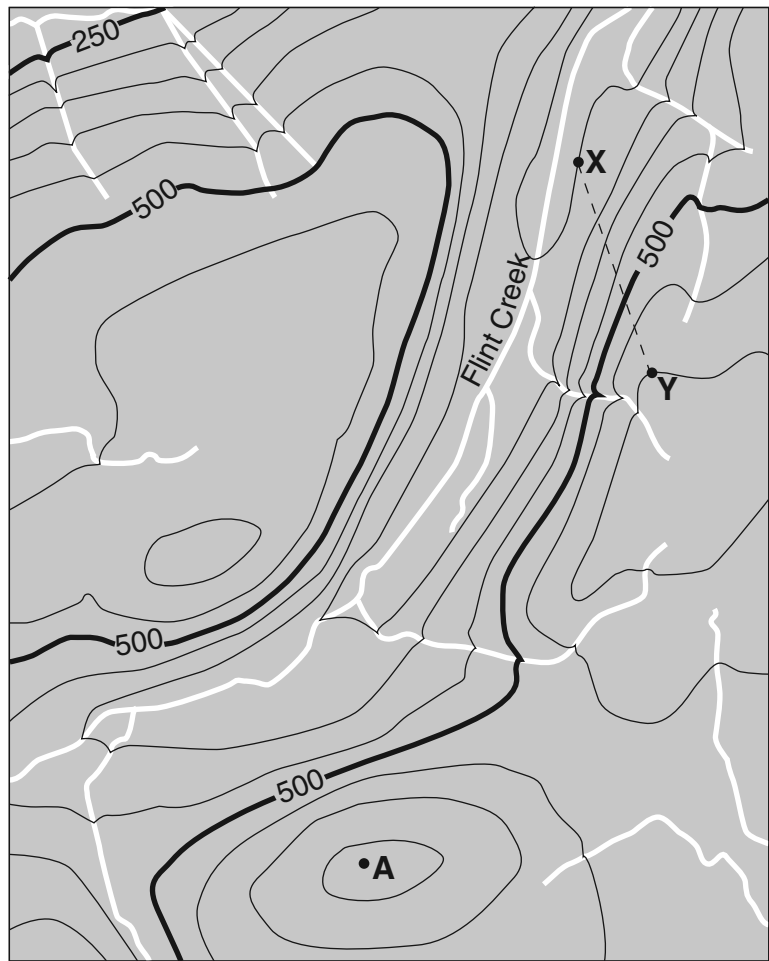

Contour interval = 50 meters 0 1 2 3 4 5 km

46 What is a possible elevation of point A?

- (1) 575 meters
- (2) 600 meters
- (3) 655 meters
- (4) 710 meters



47 In which general direction does Flint Creek flow?

- (1) southwest
- (2) southeast
- (3) northwest
- (4) northeast



48 What is the approximate gradient along the straight dashed line between points X and Y?

- (1) 50 m/km
- (2) 100 m/km
- (3) 150 m/km
- (4) 300 m/km



Base your answers to questions 49 and 50 on the diagram below, which represents the current locations of two planets, A and B, orbiting a star. Letter X indicates a position in the orbit of planet A. Numbers 1 through 4 indicate positions in the orbit of planet B.

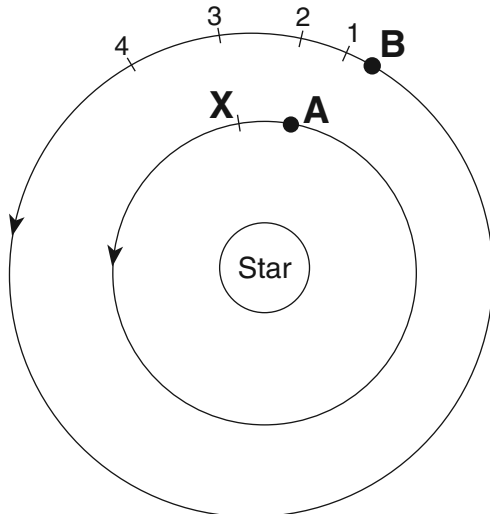

(Not drawn to scale)

49 As planet A moves in orbit from its current location to position X, planet B most likely moves in orbit from its current location to position

- (1) 1
- (2) 2

- (3) 3
- (4) 4

50 If the diagram represents our solar system and planet B is Venus, which planet is represented by planet A?

- (1) Mercury
- (2) Jupiter

- (3) Earth
- (4) Mars



Part B-2

Answer all questions in this part.

Directions (51–65): Record your answers in the spaces provided in your answer booklet. Some questions may require the use of the *2011 Edition Reference Tables for Physical Setting/Earth Science*.

Base your answers to questions 51 through 53 on the magnified views shown below of the minerals found in an igneous rock and in a metamorphic rock. The millimeter scale indicates the size of the crystals shown in the magnified views.

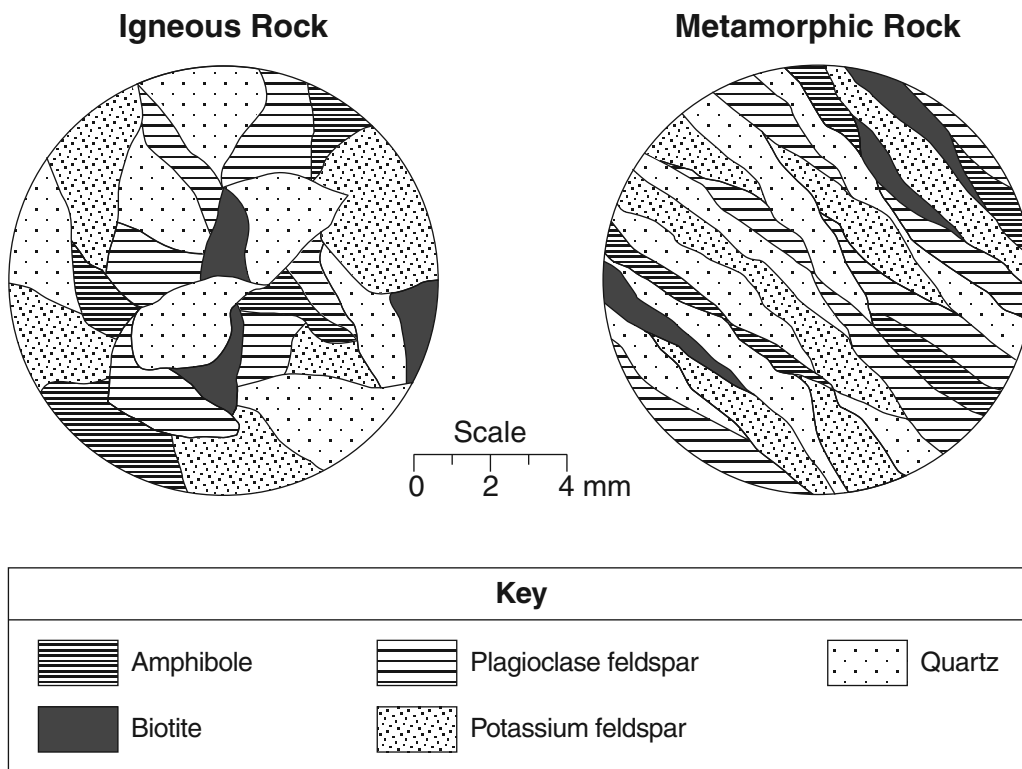

51 Identify the environment of formation of this igneous rock based on the size of its intergrown crystals. [1]



52 Based on the minerals present, identify the relative color and density of this igneous rock compared to mafic igneous rocks with the same crystal size. [1]



53 Describe the texture shown by this metamorphic rock that indicates it could be schist. [1]



Base your answers to questions 54 through 58 on the passage below.

Dinosaur Skull Offers Hints About Africa's Past

A fossil skull was found in Africa among many dinosaur bones from the Late Cretaceous Epoch. This skull came from a dinosaur named *Rugops primus*, or “first wrinkle face.” This meat eater, believed to have been about 30 feet long and to have lived 95 million years ago, belonged to a group of dinosaurs called abelisaurids.

This fossil skull, unearthed in the Sahara Desert in 2000, provides new evidence that Africa split from other southern continents at a later time than previously thought. Before this discovery, abelisaurids from that period had been found only in South America, Madagascar, and India, but not in Africa. This new fossil, *Rugops primus*, found only in Africa, indicates that Africa was still connected to the other southern landmasses, at least by a land bridge, 100 million years ago.

54 During which geologic era is *Rugops primus* inferred to have lived? [1]



55 What evidence suggests that Africa was still attached to South America 100 million years ago? [1]



56 State the type of rock in which *Rugops primus* was most likely preserved. [1]



57 *Rugops primus* is *not* a good index fossil. Describe *one* characteristic of a good index fossil. [1]



58 Identify the type of tectonic plate movement that caused Africa to separate from South America. [1]



Base your answers to questions 59 through 61 on the map in your answer booklet, which represents two bridges that cross the Green River. Letters *A*, *B*, and *C* represent locations in the river. A ball was dropped from bridge 1 at location *A* and the distance and travel time to location *B* were recorded. The results are shown in the data table below.

Travel from A to B

Distance (cm)	Time (s)
12,000	240

59 On the map *in your answer booklet*, place an **X** at the location between the bridges where the greatest amount of deposition is most likely occurring. [1]



60 Determine the rate at which the ball traveled, in centimeters per second, from location *A* to location *B*. [1]



61 After a thunderstorm, the velocity of the river at location *C* was 100 centimeters per second. What was the largest type of sediment transported by the river at this location? [1]



Base your answers to questions 62 through 65 on the diagram below. The diagram represents daytime and nighttime on Earth. Point X is a location on Earth's surface. Earth's rotational surface velocity is shown in miles per hour (mi/h) at specific latitudes.

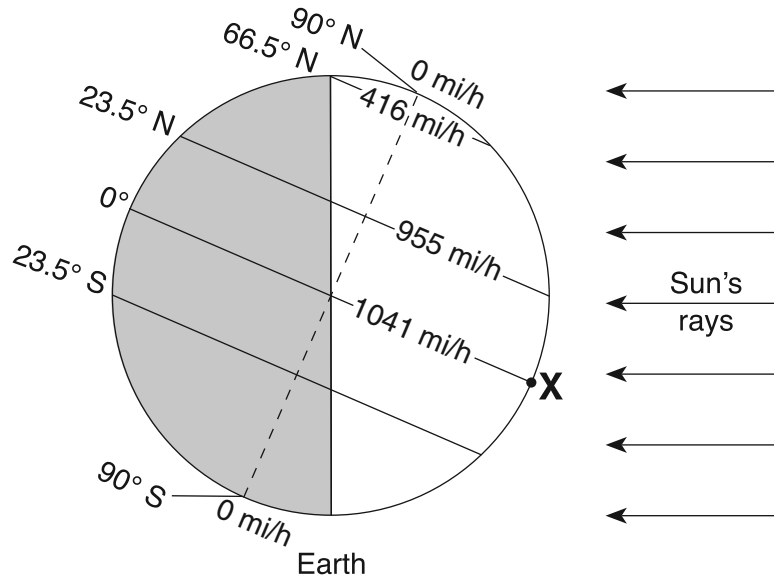

62 What is Earth's rotational surface velocity, in miles per hour, at 23.5° south latitude? [1]



63 Record, to the *nearest hour*, the duration of insolation at location X for one Earth rotation. [1]



64 On the grid *in your answer booklet*, draw a line to show the general relationship between distance from the equator and Earth's rotational surface velocity. [1]



65 Identify the Northern Hemisphere season that is just beginning when Earth is at the position represented in this diagram. [1]



Part C

Answer all questions in this part.

Directions (66–85): Record your answers in the spaces provided in your answer booklet. Some questions may require the use of the *2011 Edition Reference Tables for Physical Setting/Earth Science*.

Base your answers to questions 66 and 67 on the world map below. Points *A* through *H* represent locations on Earth's surface.

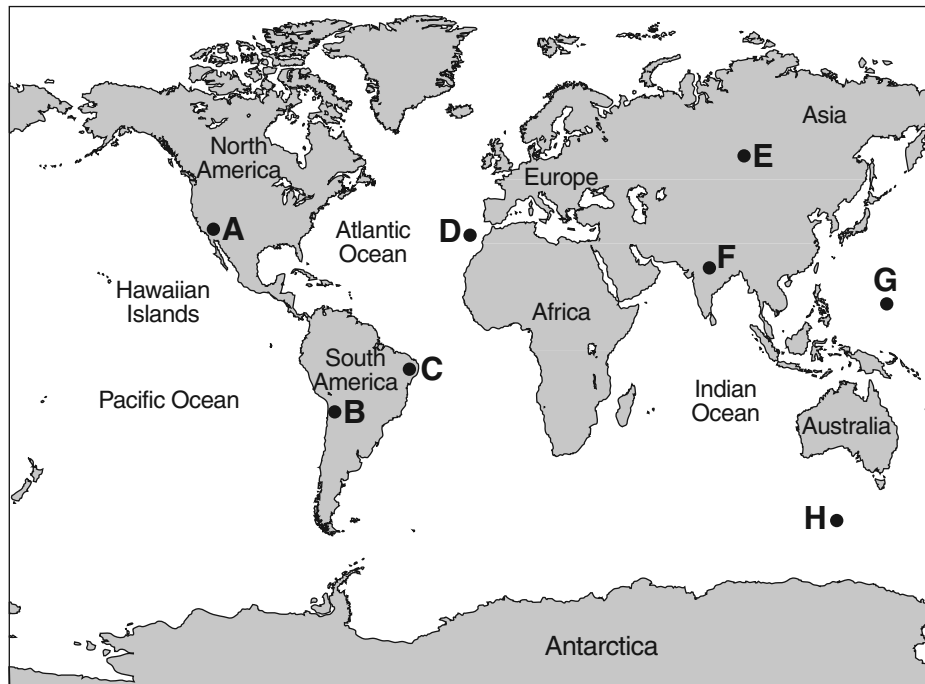

66 Identify the *two* lettered locations from the map that are *least* likely to experience volcanic activity or earthquakes. [1]

67 Identify the tectonic feature responsible for the formation of the Hawaiian Islands. [1]

Base your answers to questions 68 and 69 on the data table below and on the partial weather station model for Oklahoma City, Oklahoma, in your answer booklet.

Data Table

Visibility	7 miles
Dewpoint	48°F
Wind Direction	from the south
Wind Speed	25 knots

68 On the partial weather station model for Oklahoma City *in your answer booklet*, add the correct weather map symbols to indicate the weather conditions shown in the data table. [1]



69 State the actual barometric pressure at Oklahoma City. [1]



Base your answers to questions 70 through 72 on the geologic cross section below, which represents a portion of Earth's crust. Some rock units contain index fossils. Box A indicates a missing portion of the cross section.

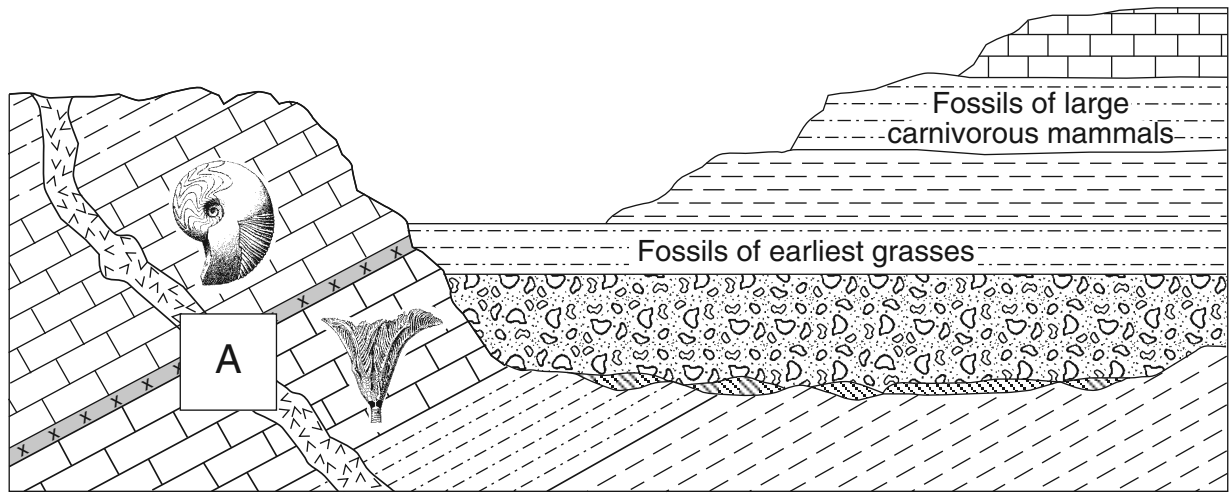

Key	
	Volcanic ash
	Meteor impact debris
	Basaltic intrusion

70 In the box that represents box A on the cross section *in your answer booklet*, draw *both* the volcanic ash layer and the basaltic intrusion to clearly show their relative age. [1]

71 Describe *one* piece of evidence which indicates that the horizontal rock layers are younger than the tilted rock layers. [1]

72 The meteor impact debris was deposited at the time trilobites became extinct. State the age, in million years, of this debris layer. [1]

Base your answers to questions 73 and 74 on the map in your answer booklet, which represents the center of a low-pressure system indicated by **L**. The 1000-millibar (mb) isobar is drawn around the center of this low-pressure system.

73 On the map *in your answer booklet*, draw *two* additional isobars around the outside of the 1000-mb isobar  in a way that indicates that the strongest winds are west of the low-pressure center. [1]

74 Identify *one* factor that usually causes many low-pressure centers to generally move from west to east across the United States. [1]

Base your answers to questions 75 and 76 on the map below, which represents the geographic source regions of two air masses, X and Y. The arrows represent the convergence of these air masses, which may result in tornadoes.

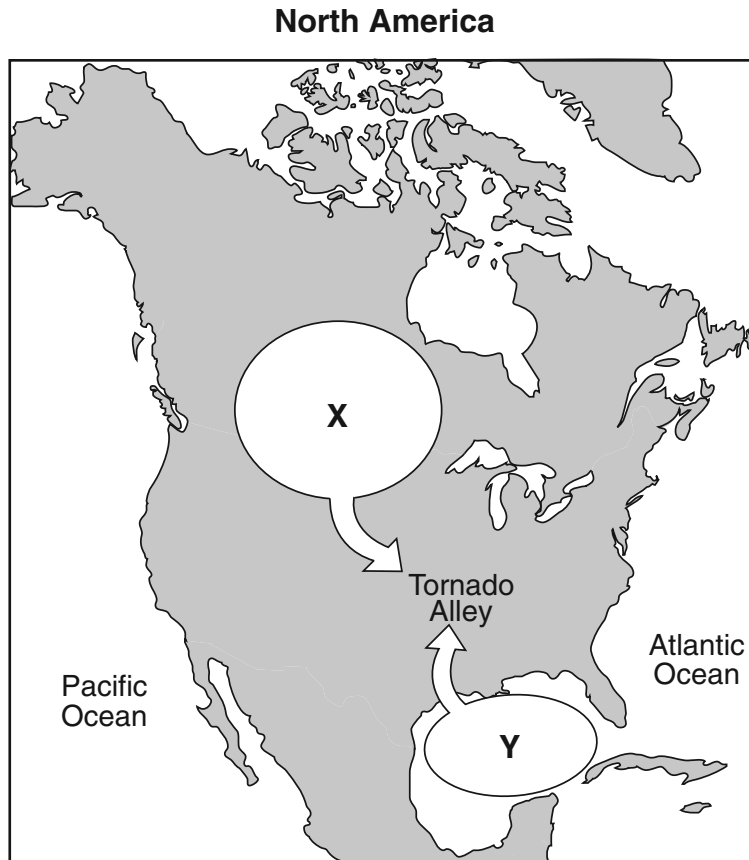





75 Use the standard two-letter air-mass symbols to identify air-masses X and Y. [1]



76 A tornado watch or warning is issued for a location in the area labeled Tornado Alley. State *one* safety precaution that should be taken to avoid possible injury from this tornado. [1]

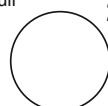
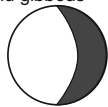

Base your answers to questions 77 through 82 on the calendar and data table below. The calendar shows the month of February 2007, indicating the dates when some lunar phases occurred. February 24 lists only the name of the Moon phase that occurred on that day. The data table shows the highest and lowest tides (in feet) recorded for the Hudson River at Kingston, New York, over a 2-day period in February 2007.

February 2007						
Sun	Mon	Tue	Wed	Thu	Fri	Sat
				1	Full 2 	3
4	5	Old gibbous 6 	7	8	9	Last quarter 10 
11	12	13	14	15	16	New 17 
18	19	New crescent 20 	21	22	23	First quarter 24
25	26	27	28			

High and Low Tides for Kingston, New York

Date	Time of Day	Tide Height (ft)
Friday, February 2	1:30 a.m.	3.5
	7:30 a.m.	-0.2
	1:30 p.m.	4.1
	8:00 p.m.	-0.4
Saturday, February 3	2:00 a.m.	3.6
	8:30 a.m.	-0.2
	2:00 p.m.	4.0
	9:00 p.m.	-0.4

77 On the grid *in your answer booklet*, plot the tide height for *each* time of day listed in the data table. Connect the plots with a line. [1]

78 Predict the time of the first high tide on Sunday, February 4. Include a.m. or p.m. in your answer. [1]

79 On the diagram *in your answer booklet*, draw a small circle (O) on the Moon's orbit to show the position of the Moon in its orbit on February 2. [1]

80 State the date of the next full Moon that occurred after February 2. [1]

81 In the circle *in your answer booklet*, shade the part of the Moon that appeared dark to an observer in New York State on February 24. [1]

82 Determine the altitude of *Polaris* at Kingston, New York, to the *nearest degree*. [1]

Base your answers to questions 83 through 85 on the passage below.

Mount Manaro Erupts!

Mount Manaro is a volcano on Ambae Island, about 1400 miles northeast of Australia. Ambae Island is located in the South Pacific Ocean at 15° south latitude, 168° east longitude.

After Mount Manaro had erupted in 1995, Ambae Island residents developed an evacuation plan. When Mount Manaro began erupting gas, steam, and ash on November 27, 2005, scientists and residents watched the volcano carefully.

The eruption became more severe on December 9, 2005, when steam and gases rose 1.8 miles up into the air. Rocks and ash began to fall on nearby farms and homes. Thousands of people left their homes, making it the largest evacuation ever on Ambae Island.

83 Name the highest layer of the atmosphere into which the steam from the volcanic eruption rose on December 9, 2005. [1]

84 Identify the ocean current off the northeast coast of Australia that most affects the climate of Ambae Island. [1]

85 On the diagram *in your answer booklet*, draw *one* arrow through point X and *one* arrow through point Y to indicate the direction of tectonic plate motion near Mount Manaro. [1]

Part B–2

Allow a maximum of 15 credits for this part.

- 51** [1] Allow 1 credit. Acceptable responses include, but are not limited to:
- intrusive
 - plutonic
 - underground
- 52** [1] Allow 1 credit if *both* the color and density are correct. Acceptable responses include, but are not limited to:
- Color:
- lighter
 - whiter
 - pinker
- Density:
- lower
 - less dense
- 53** [1] Allow 1 credit. Acceptable responses include, but are not limited to:
- foliated
 - mineral alignment
 - flattened crystals

- 54** [1] Allow 1 credit for Mesozoic Era.
- 55** [1] Allow 1 credit. Acceptable responses include, but are not limited to:
- Similar fossil remains are found in Africa and South America.
 - The fossil *Rugops primus*, found in Africa, is related to abelisaurids found in South America and India.
 - fossil evidence
- 56** [1] Allow 1 credit for sedimentary rock *or* any specific sedimentary rock, such as shale.
- 57** [1] Allow 1 credit. Acceptable responses include, but are not limited to:
- wide geographic distribution *or* widespread
 - lived a short period of geologic time *or* short lived
 - easily recognizable
- 58** [1] Allow 1 credit. Acceptable responses include, but are not limited to:
- divergence
 - rifting
 - seafloor spreading

59 [1] Allow 1 credit if the center of the **X** is located within the area indicated below.

Note: It is recommended that an overlay of the same scale as the student answer booklet be used to ensure reliability in rating.

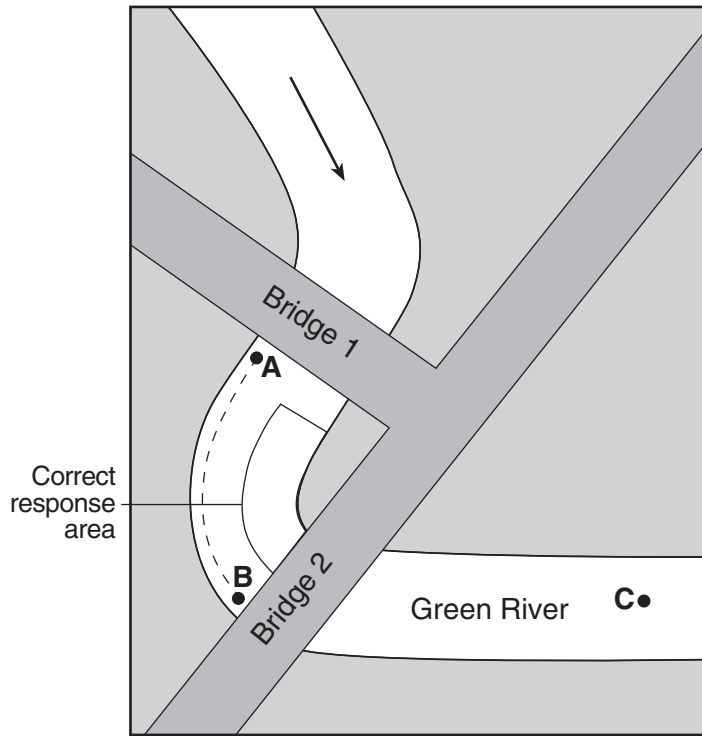

60 [1] Allow 1 credit for 50 cm/s.

61 [1] Allow 1 credit. Acceptable responses include, but are not limited to:

- pebbles
- 2-cm to 3-cm-diameter particles

62 [1] Allow 1 credit for 955 mi/h.

63 [1] Allow 1 credit for 12 h.

64 [1] Allow 1 credit for a graph that shows an inverse relationship.

Examples of 1-credit graphs:

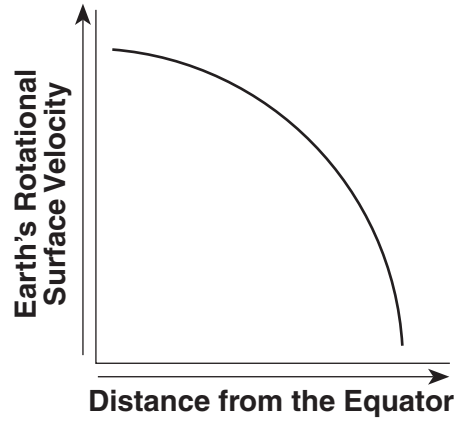
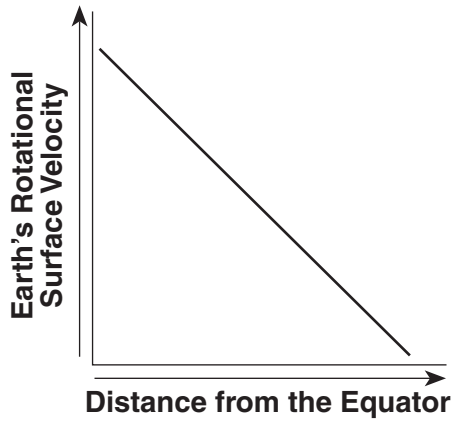

65 [1] Allow 1 credit for summer.

Part C

Allow a maximum of 20 credits for this part.

66 [1] Allow 1 credit for *C* and *E*.

67 [1] Allow 1 credit. Acceptable responses include, but are not limited to:

- Hawaii Hot Spot
- mantle hot spot
- volcano
- a rising magma plume

68 [1] Allow 1 credit if *all four* weather variables from the data table are correctly recorded in the proper format. Allow credit if feathers are drawn on either side of the staff.

Example of a 1-credit response:

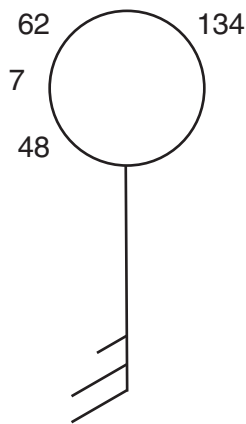

69 [1] Allow 1 credit for 1013.4 mb.

70 [1] Allow 1 credit for a response showing the basaltic intrusion cutting through the ash layer.

Example of a 1-credit response:

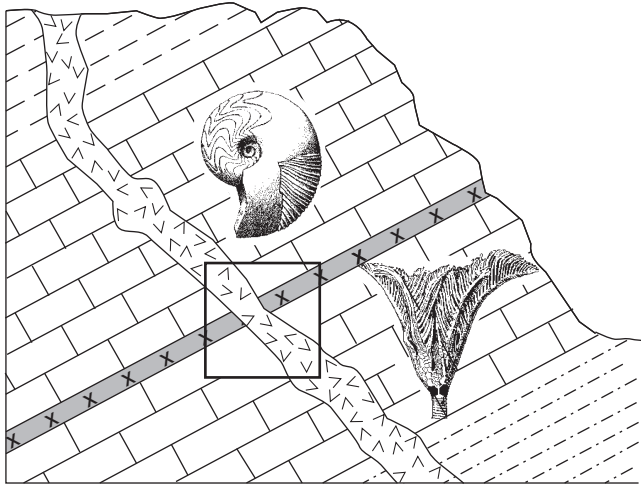

71 [1] Allow 1 credit. Acceptable responses include, but are not limited to:

- The horizontal rocks are on top of the tilted layers.
- Fossils of the earliest grasses and large carnivorous mammals are more recent than *Manticoceras* and *Ctenocrinus*.
- The fossils in the tilted layers are older.

72 [1] Allow 1 credit for 251 million years.

- 73 [1] Allow 1 credit for correctly drawing the *two* isobars. The isobars should be closer together on the western side. If additional isobars are drawn, all must be correct to receive credit.

Example of a 1-credit response:

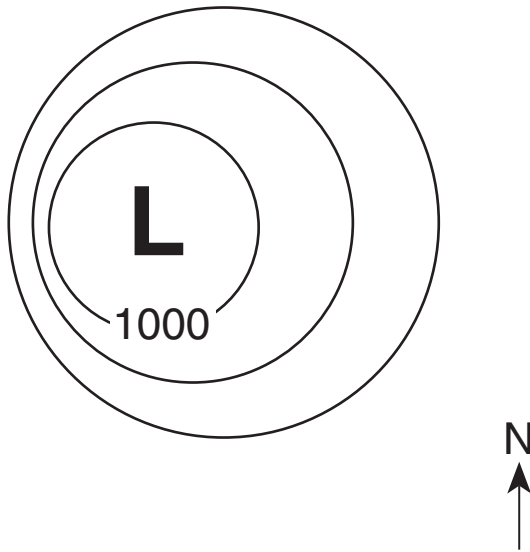

- 74 [1] Allow 1 credit. Acceptable responses include, but are not limited to:
- the prevailing southwest winds
 - the jet stream
 - planetary winds
- 75 [1] Allow 1 credit for a correct response for *both* air-mass symbols. Allow credit even if all uppercase letters are used.
- Air-mass X: cP *or* cA
 - Air-mass Y: mT

Note: Do *not* allow credit if the letters are reversed, such as Pc.

- 76 [1] Allow 1 credit. Acceptable responses include, but are not limited to:
- go to the basement
 - stay away from windows
 - listen to emergency warnings broadcast on radio or TV
 - go to a community emergency shelter

77 [1] Allow 1 credit if the centers of *all eight* plots are located within the circles shown below and are connected with a line that passes within each circle.

Note: It is recommended that an overlay of the same scale as the student answer booklet be used to ensure reliability in rating.

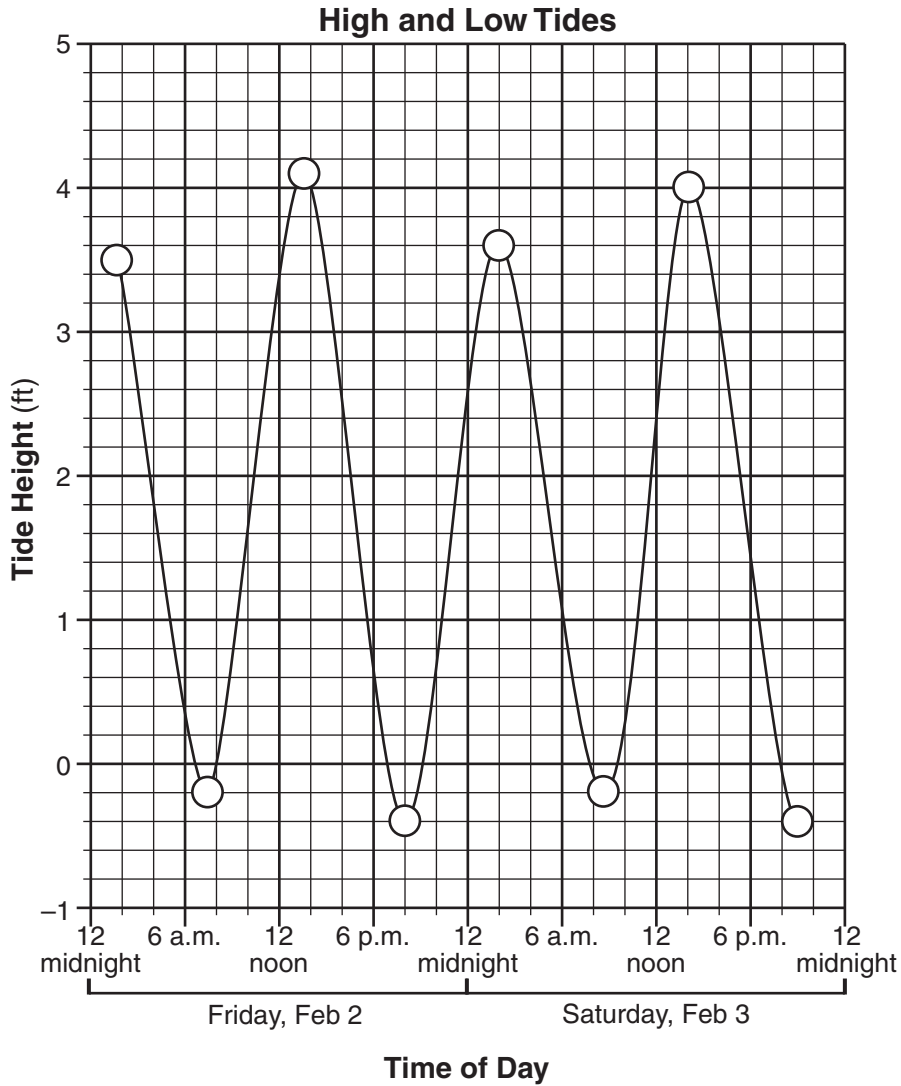

78 [1] Allow 1 credit for any time from 2 a.m. to 4 a.m.

79 [1] Allow 1 credit if the center of the student-drawn circle is within the brackets shown below.

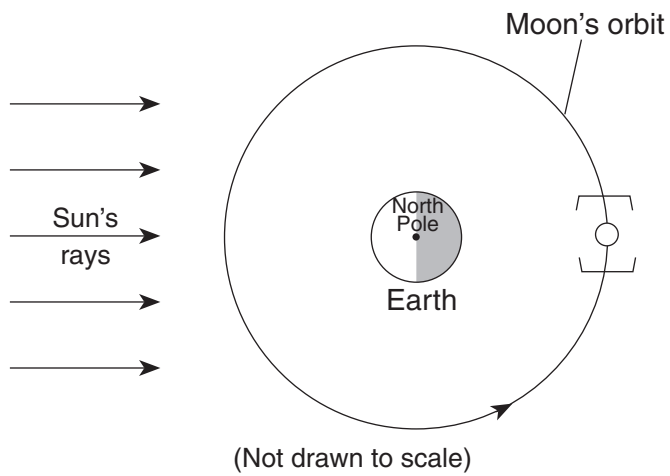

80 [1] Allow 1 credit for March 3 *or* March 4.

81 [1] Allow 1 credit for shading half of the circle on the left side.

Examples of 1-credit responses:

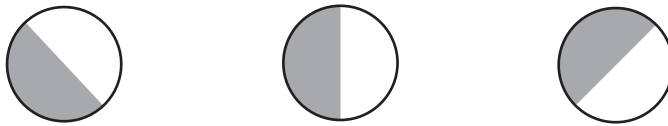

82 [1] Allow 1 credit for 42° .

83 [1] Allow 1 credit for troposphere.

84 [1] Allow 1 credit. Acceptable responses include, but are not limited to:

- East Australia Current
- South Equatorial Current
- E. Australia C.

85 [1] Allow 1 credit if *both* arrows show the correct directions, even if the arrows do *not* pass through the dots.

Example of a 1-credit response:

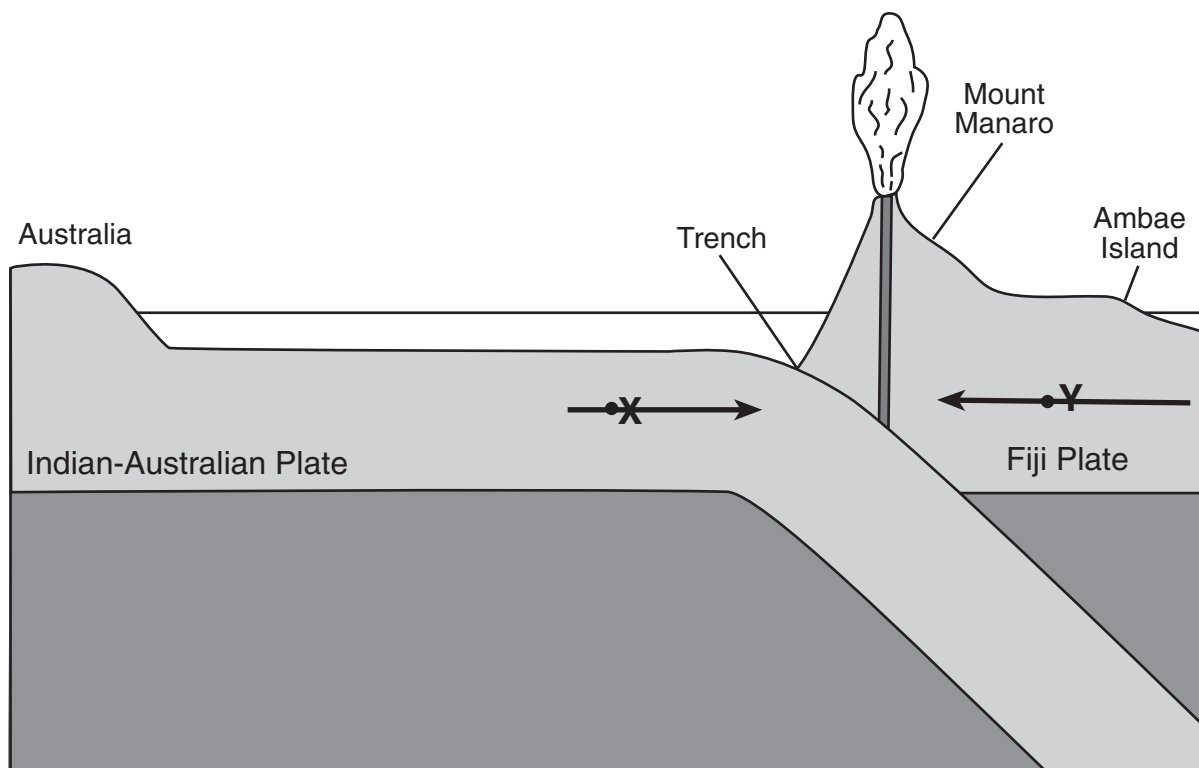

(Not drawn to scale)